

22 47 16 - 1.2B PRESSURE WATER COOLERS SD

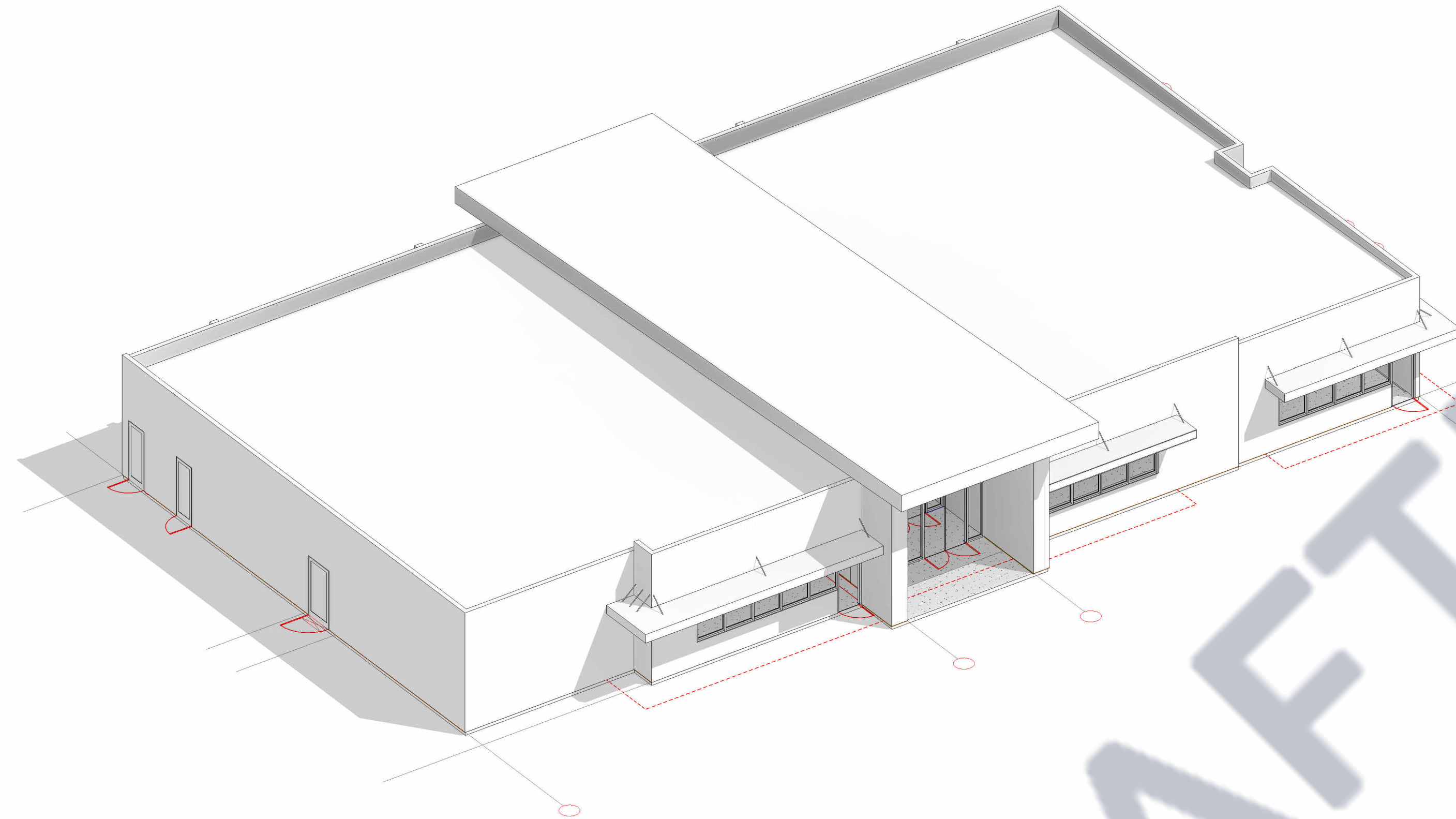

St. Jude's Healing Center Education Building

115 Healing Circle, Boulder City, NV 89005.

Submitted by



LICENSE NUMBER: NV #0086266 - & NV #0087531

Date	
Description	
No.	

CLIENT:



**CLARK COUNTY
SCHOOL DISTRICT**
OFFICE: (+1) 702-799-8710
CLARK COUNTY SCHOOL
DISTRICT

SUB CONTRACTOR:



LICENSE NUMBER : NV #0086266 - & #0087531
SHOP DRAWINGS DATE: Issue Date

NOTES:

St. Jude's Healing
Center Education
Building

115 Healing Circle,
Boulder City, NV
89005.

COVER SHEET

Project Number	2020157
Date	Issue Date
Drawn By	Author
Checked By	Checker

PWC-00
Scale 1/16" = 1'-0"

Model: LZWS-LRPB28K

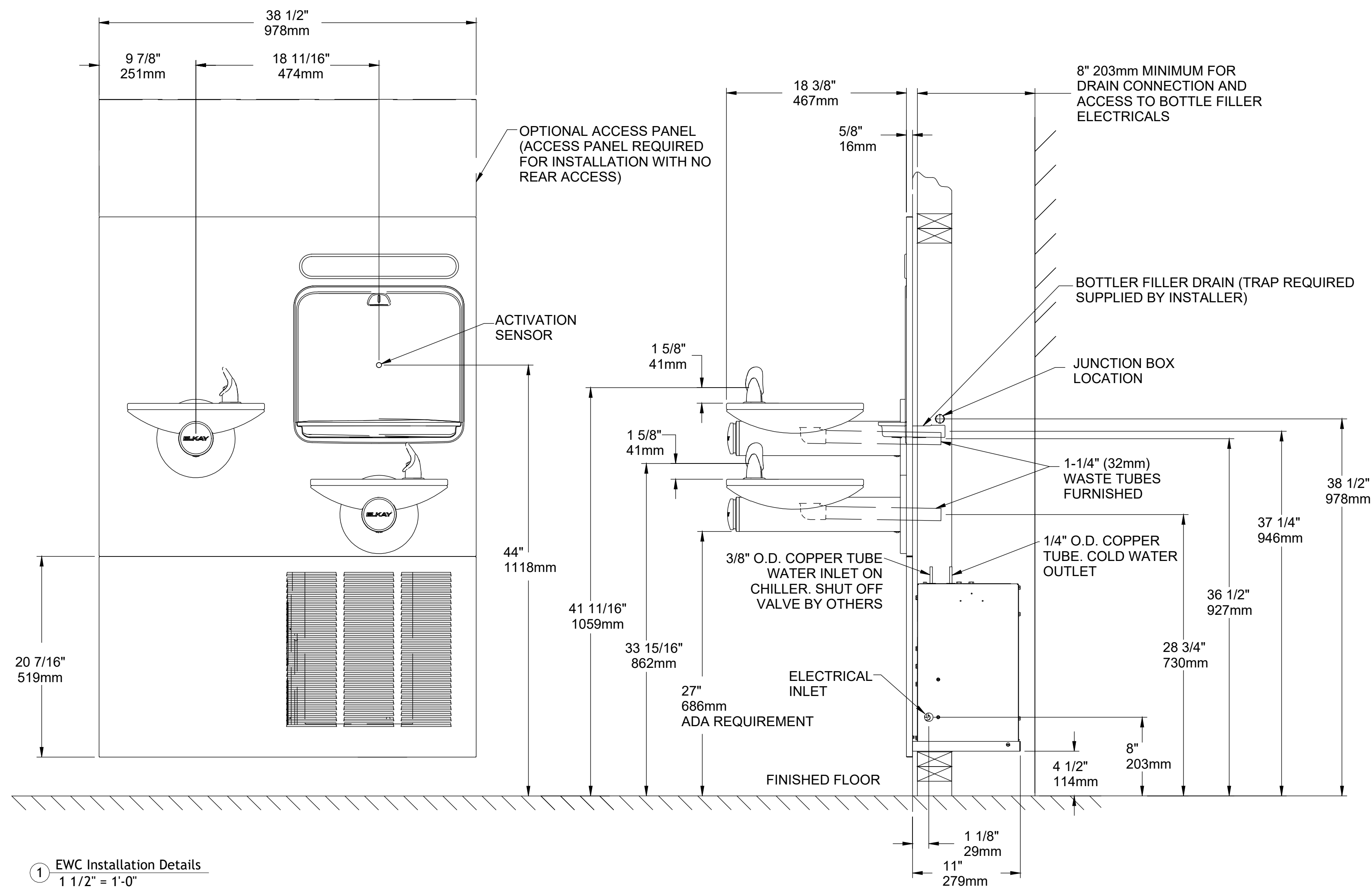

① EWC Installation Details
1 1/2" = 1'-0"

WIRING DIAGRAM

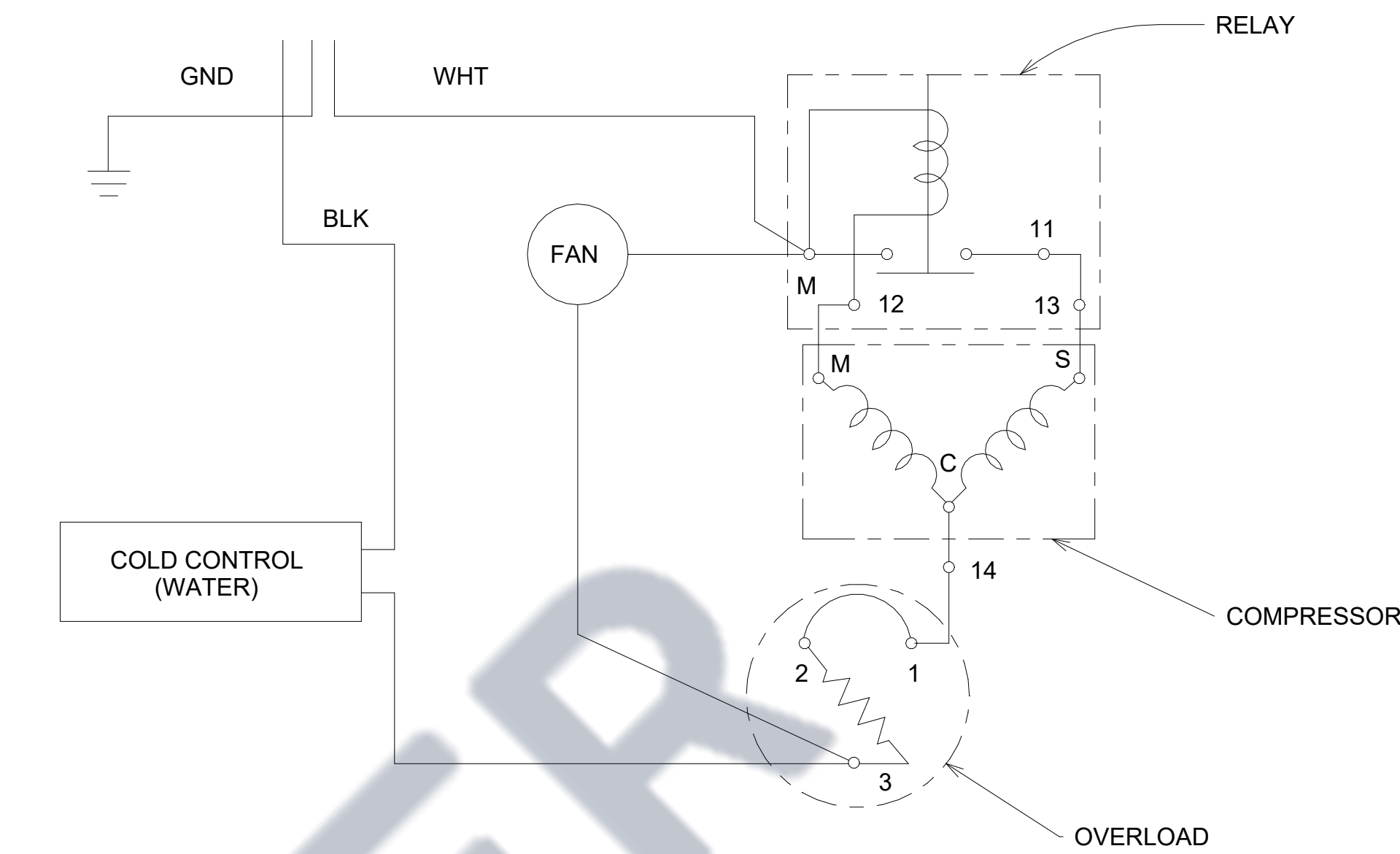

⑤ WIRING DIAGRAM
1 1/2" = 1'-0"

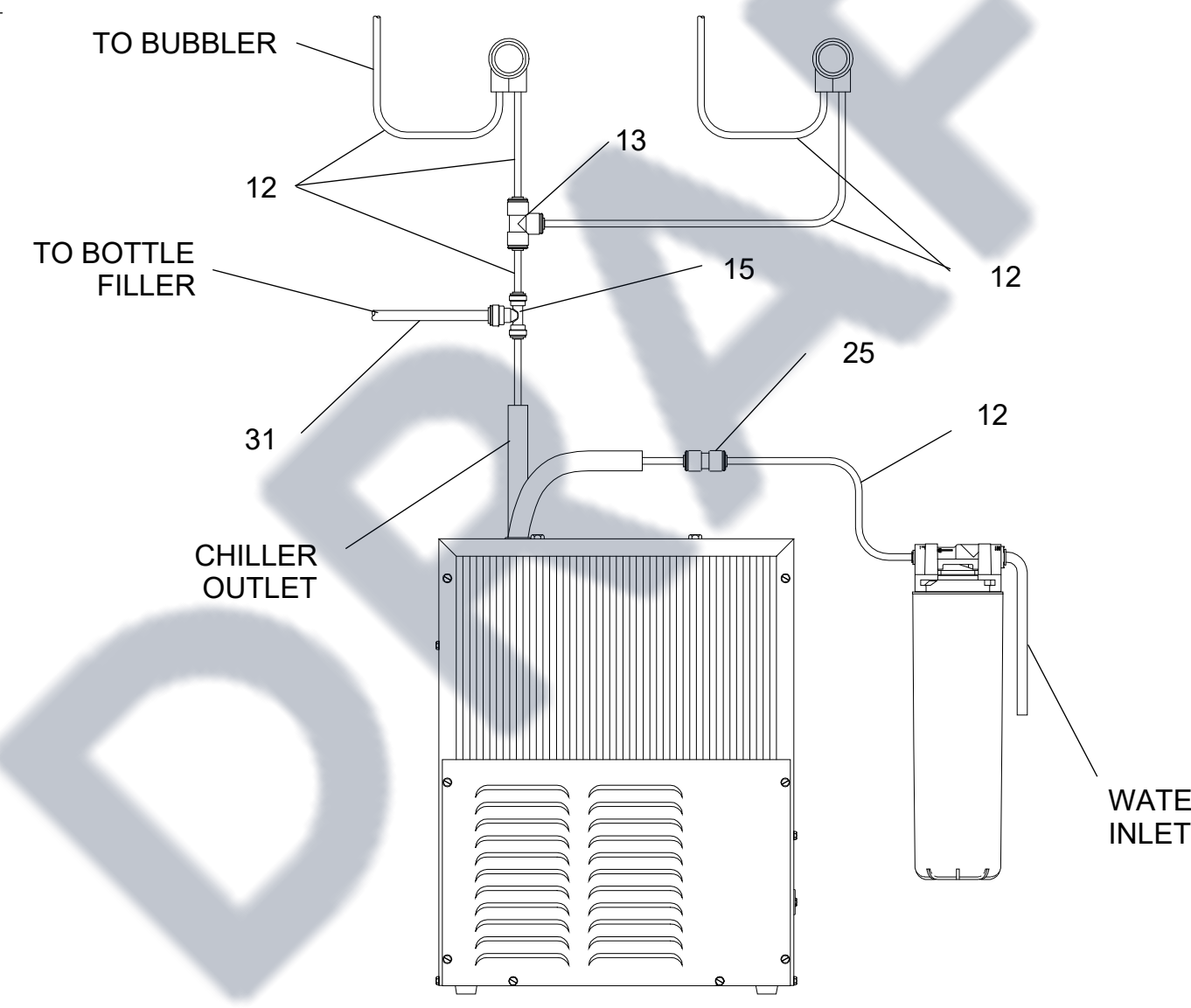

LZWS-LRPB Tube Routing

② EWC LZWS-LRPB Tube Routing
1 1/2" = 1'-0"

MFWS210 / MFWS230 MOUNTING FRAME INSTRUCTIONS

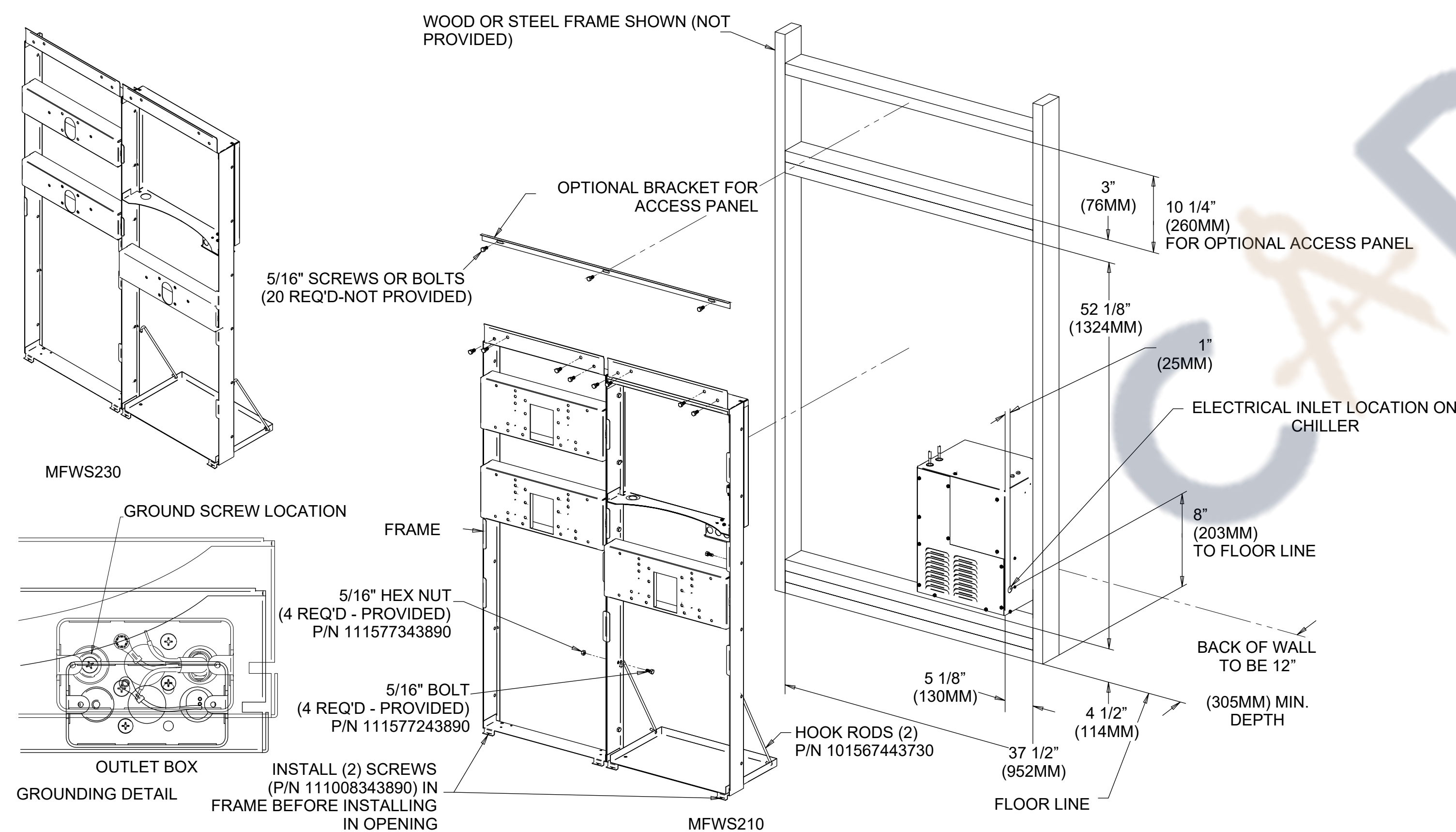

④ EWC MOUNTING FRAME INSTRUCTIONS
1 1/2" = 1'-0"

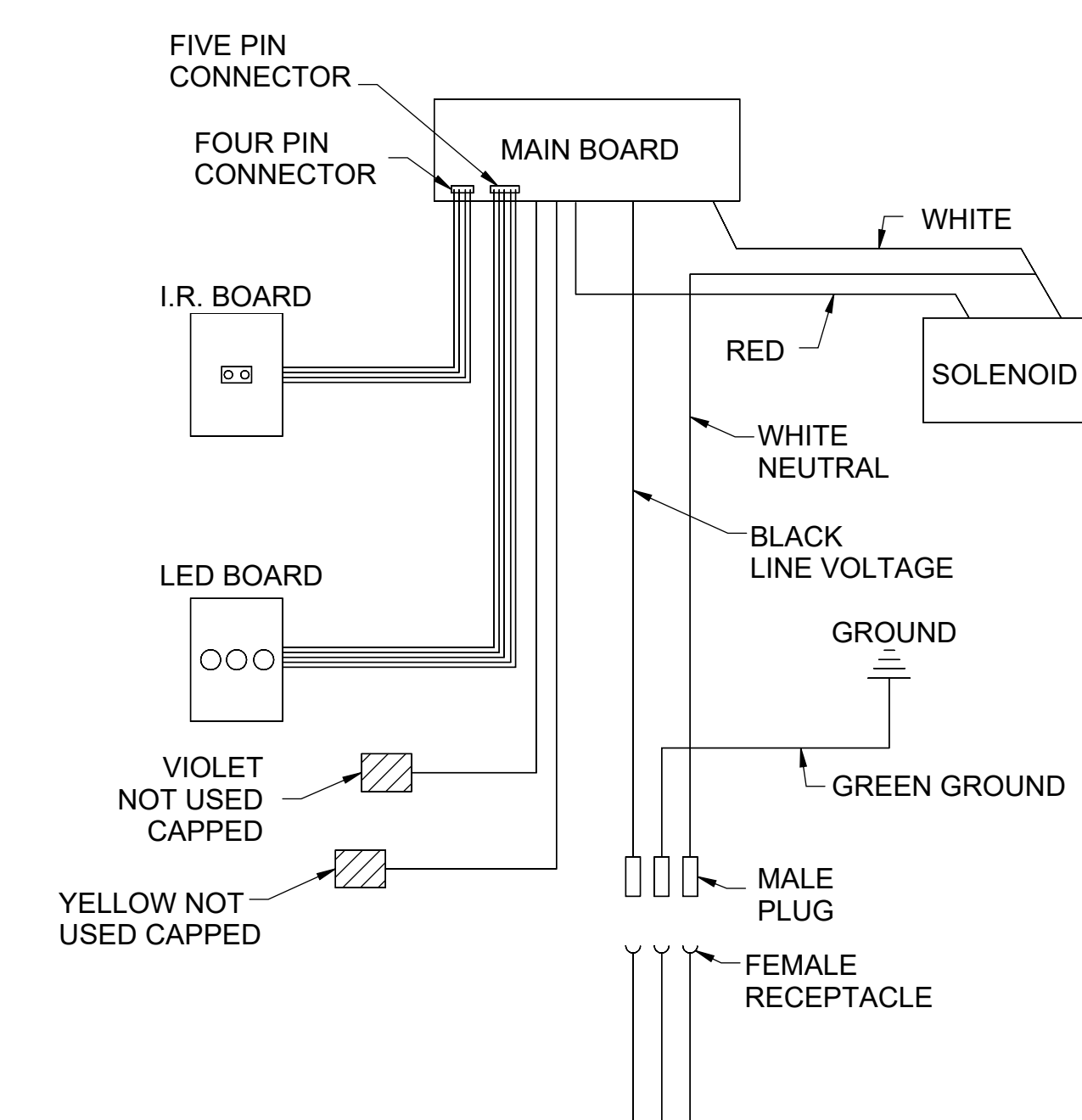

Electrical Diagram

③ EWC Electrical Diagram
1 1/2" = 1'-0"

Specifications

MATERIAL	Stainless Steel
Number of Stations	2
Features	Antimicrobial Green Ticker™ Hands Free Laminar Flow Real Drain
Power	115V/60Hz
Dimensions	L: 38-1/2" W: 19" H: 55-1/16"
Bubbler Style	Flexi-Guard © Safety Bubbler
Mounting Option	Wall Mount (Inwall Frame/Plate)
Chilling Capacity	8.0 GPH
Installation Location	Indoor
Shipping Dimensions	L: 59-3/4" W: 60-3/4" H: 39-7/8"
Included with Product	Fountain with Integral Bottle Filling Station (ERPBD28WSC) Mounting Frame (MFWS210) Chiller (ECH8)
Ships In Multiple Boxes	Yes
Made or Assembled USA	built
Family	SwirlFlo
ADA	Yes
Filtered	No
Code Compliance Drinking Solutions	ADA & ICC A117.1 ASME A112.19.3/CSA B45.4 CAN/CSA C22.2 No. 120 GreenSpec NSF 372 (lead free) NSF 61 UL 399
Note	Non-filtered model

Date	
Description	
No.	

CLIENT:
CCSD
CLARK COUNTY
SCHOOL DISTRICT
OFFICE: (+1) 702-799-8710
 CLARK COUNTY SCHOOL DISTRICT

SUB CONTRACTOR:

RED MESA
 MECHANICAL

LICENSE NUMBER : NV #0086266 - & #0087531
 SHOP DRAWINGS DATE: Issue Date

NOTES:

St. Jude's Healing Center Education Building
 115 Healing Circle,
 Boulder City, NV
 89005.

22 47 16-1.2B
PRESSURE WATER
COOLERS DETAILS

Project Number 2020157
 Date Issue Date
 Drawn By Author
 Checked By Checker

PWC-02
 Scale As indicated